

4.6 Entering To The Programming Mode, Changing and Saving Parameters

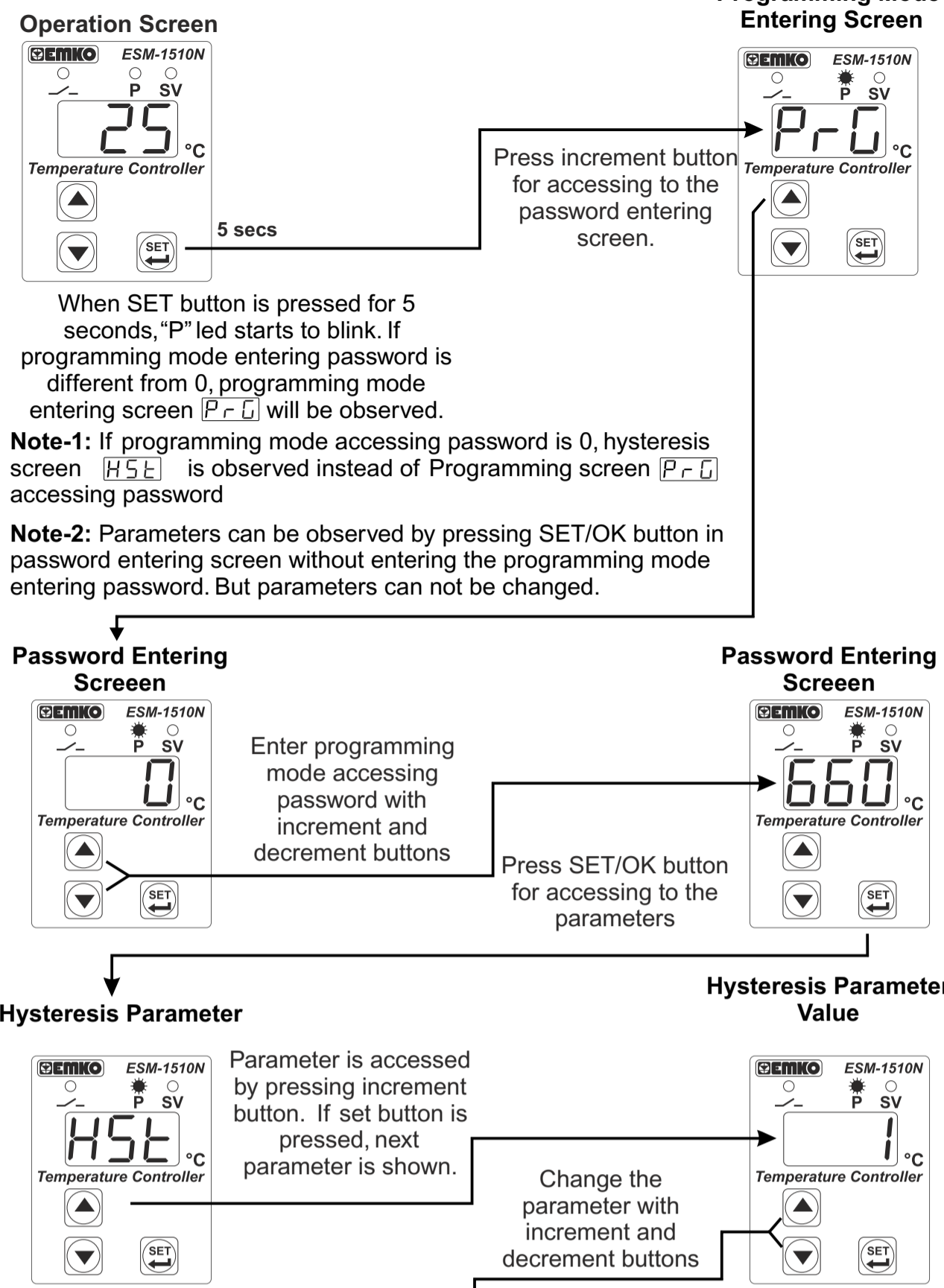

If no operation is performed in Programming mode for 20 seconds, device turns to operation screen automatically

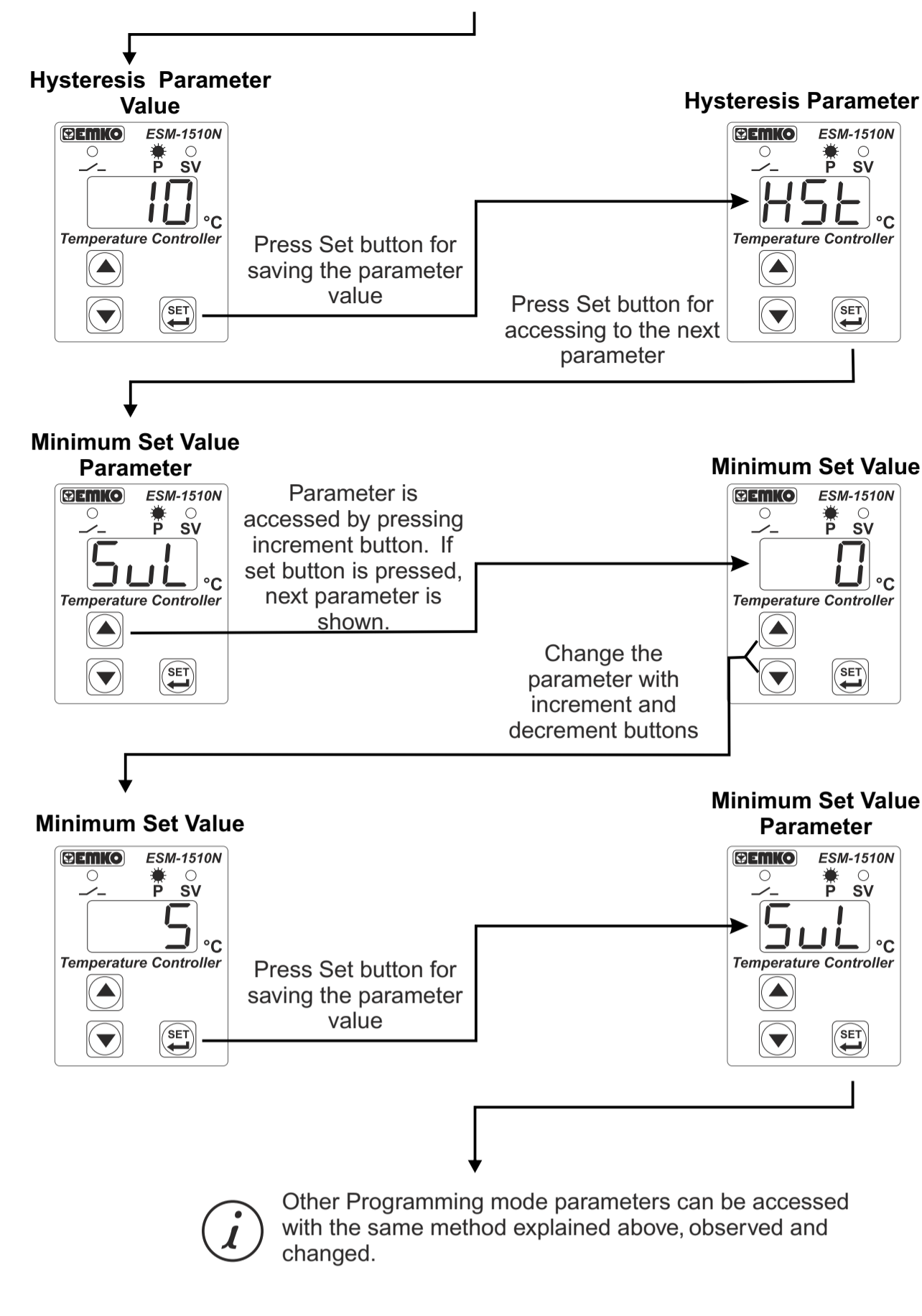

Other Programming mode parameters can be accessed with the same method explained above, observed and changed.

If no operation is performed in Programming mode for 20 seconds, device turns to operation screen automatically

5. Failure Messages in ESM-1510N Temperature Controller

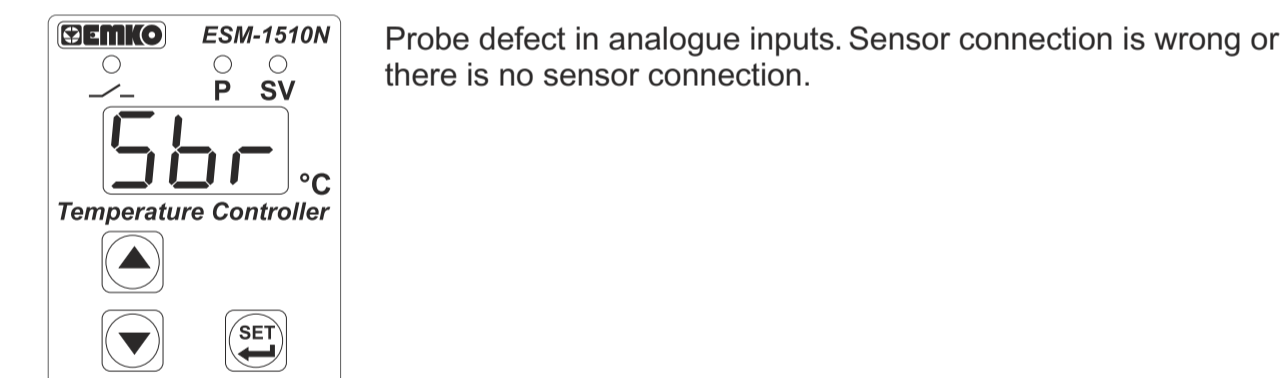

6. Ordering Information

ESM-1510N	A	B	C	D	E	F	G	H	I	J	K	L	M	N	O
	0	0	0	0	0	0	0	0	0	0	0	0	0	0	0

A Supply Voltage
1 100-240V ~ (-15%,+10%) 50/60Hz - 2.5 VA
2 24V ~ (-15%,+10%) 50/60Hz - 2.5 VA
3 24V ~ (±15%) 50/60Hz - 2.5 VA
4 115V ~ (±15%) 50/60Hz - 2.5 VA
5 230V ~ (±15%) 50/60Hz - 2.5 VA
8 10...30V ~ - 2.5W
9 Customer

BC Input Type	Scale(°C)
05 J, Fe CuNi IEC584.1(ITS90)	0°C 800°C
10 K, NiCr Ni IEC584.1(ITS90)	0°C 999°C
11 PT 100, IEC751(ITS90)	-50°C 400°C
09 PT 100, IEC751(ITS90)	-19.9°C 99.9°C
12 PTC (Note-1) (Note-2)	-50°C 150°C
14 PT 1000, IEC751(ITS90)	-50°C 400°C
13 PT 1000, IEC751(ITS90)	-19.9°C 99.9°C
18 NTC (Note-1) (Note-2)	-50°C 100°C

Note-1: Selectable decimal type for PTC and NTC via parameter (Scale: -19.9...99.9°C)

Note-2: If input type is selected PTC or NTC (BC = 12, 18), Temperature sensor is given with the device. For this reason, If input type is selected as PTC, sensor type (V = 0, 1 or 2) or If input type is selected as NTC, sensor type (V = 0, 3 or 4) must be declared in ordering information.

E Output-1
1 Relay Output (resistive load 10 A@250V ~, 1 NO + 1 NC)
2 SSR Driver Output (Maximum 28 mA, 15 V ~)

V Temp. Sensor which is given with ESM 1510
0 None
1 PTC-M6L40.K1.5 (PTC Air Probe with 1.5 m silicon cable)
2 PTCS-M6L30.K1.5.1/8" (PTC Liquid Probe with 1.5 m silicon cable)
3 NTC-M5L20.K1.5 (NTC Probe, thermoplastic moulded with 1.5 m cable for cooling application)
4 NTC-M6L50.K1.5 (NTC Probe, stainless steel housing with 1.5 m cable for cooling application)
9 Customer

All order information of ESM-1510N Temperature Controller are given on the table at left. User may form appropriate device configuration from information and codes that at the table and convert it to the ordering codes.

Firstly, supply voltage then other specifications must be determined. Please fill the order code blanks according to your needs.

Please contact us, if your needs are out of the standards.

~ Symbol means Vac,
 ~ Symbol means Vdc,
 ~ Symbol means Vac/dc

7. Specifications

Device Type : Temperature Controller
Housing&Mounting : 86mm x 35mm x 59mm plastic housing for Rail Mounting.
Protection Against Mechanical Impacts : 1Joule (IK06)
Protection Class : IP20.
Weight : Approximately 0.14 Kg.
Environmental Ratings : Standard, indoor at an altitude of less than 2000 meters with none condensing humidity.
Storage / Operating Temperature : -40°C to +85°C / -30°C to +80°C
Storage / Operating Humidity : 90 % max. (None condensing)
Installation : DIN Rail Mounting
Overvoltage Category : II.
Pollution Degree : II, office or workplace, none conductive pollution
Operating Conditions : Continuous
Supply Voltage and Power : 100-240 V~ (-%15, +%10) 50/60 Hz - 2.5VA
 230 V~ (±15%) 50/60 Hz - 2.5VA
 115 V~ (±15%) 50/60 Hz - 2.5VA
 24 V~ (±15%) 50/60 Hz - 2.5VA
 24 V~ (±15%) 50/60 Hz - 2.5VA
 10...30 V~ - 2.5W

Temperature Sensor Inputs : NTC, PTC, TC, RTD
NTC Input Type : NTC (10 kΩ @ 25 °C)
PTC Input Type : PTC (1000 Ω @ 25 °C)
Thermocouple Input Types : J, K (IEC584.1)(ITS90)
Thermoresistance Input Type : PT-100, PT-1000 (IEC751)(ITS90)
Accuracy : ±1% of full scale for thermocouple and thermoresistance
Cold Junction Compensation : Automatically ± 0.1 C/1 C.
Sensor Break Protection : Upscale
Sampling Cycle : 3 samples per second
Control Form : ON / OFF
Relay Output : Resistive Load 5 A@250 V ~ (Electrical Life : 100.000 operation (Full Load))
Optional SSR Output : Maximum 28 mA, Maximum 15 V ~
Display : 9 mm Red 3 digits LED Display
Leds : SV (Green) , OUT (Red) , P (Red) 3 mm
Approvals : CE, UK, ENEC

8. Manufacturer Company

Manufacturer Information:
 Emko Elektronik Sanayi ve Ticaret A.Ş.
 Bursa Organize Sanayi Bölgesi, (Fethiye OSB Mah.) Ali Osman Sönmez Bulvarı, 2. Sokak, No:3
 16215 BURSA - TÜRKİYE
 Phone : +90 224 261 1900 / Fax: +90 224 261 1912

Repair and maintenance service information:
 Emko Elektronik Sanayi ve Ticaret A.Ş.
 Bursa Organize Sanayi Bölgesi, (Fethiye OSB Mah.) Ali Osman Sönmez Bulvarı, 2. Sokak, No:3
 16215 BURSA - TÜRKİYE
 Phone : +90 224 261 1900 / Fax: +90 224 261 1912

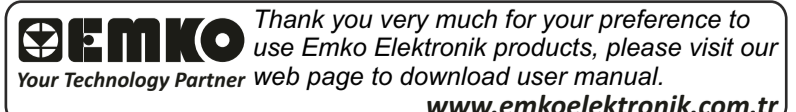

ESM-1510N DIN Rail Mounting Temperature Controller



ESM-1510N DIN Rail Mounting Type Digital, ON / OFF Temperature Controller

- 3 Digits display
- NTC Input or, PTC Input or, J type thermocouple Input or, K type thermocouple Input or, 2-Wire PT 100 Input or, 2-Wire PT 1000 Input (It must be determined in order)
- ON/OFF temperature control
- Selectable heating or cooling function
- Selection of operation with hysteresis
- Adjustable temperature offset
- Set value low limit and set value high limit boundaries
- Relay or SSR driver output
- Operation selection of compressor operates continuously, stops or operates periodically in case of probe defect
- Compressor protection delays
- Password protection for programming mode

1.3 Installation

Before beginning installation of this product, please read the instruction manual and warnings below carefully.

- In package ,
- One piece unit
 - One piece rail lock apparatus
 - One piece instruction manual

A visual inspection of this product for possible damage occurred during shipment is recommended before installation. It is your responsibility to ensure that qualified mechanical and electrical technicians install this product.

If there is danger of serious accident resulting from a failure or defect in this unit, power off the system and separate the electrical connection of the device from the system.

The unit is normally supplied without a power supply switch or a fuse. Use power switch and fuse as required.

Be sure to use the rated power supply voltage to protect the unit against damage and to prevent failure.

Keep the power off until all of the wiring is completed so that electric shock and trouble with the unit can be prevented.

Never attempt to disassemble, modify or repair this unit. Tampering with the unit may result in malfunction, electric shock or fire.

Do not use the unit in combustible or explosive gaseous atmospheres.

During the equipment is putted in hole on the metal panel while mechanical installation some metal burrs can cause injury on hands, you must be careful.

Montage of the product on a system must be done with it's fixing clamps. Do not do the montage of the device with inappropriate fixing clamp. Be sure that device will not fall while doing the montage.

It is your responsibility if this equipment is used in a manner not specified in this instruction manual.

1.4 Warranty

EMKO Elektronik warrants that the equipment delivered is free from defects in material and workmanship. This warranty is provided for a period of two years. The warranty period starts from the delivery date. This warranty is in force if duty and responsibilities which are determined in warranty document and instruction manual performs by the customer completely.

1.5 Maintenance

Repairs should only be performed by trained and specialized personnel. Cut power to the device before accessing internal parts. Do not clean the case with hydrocarbon-based solvents (Petrol, Trichlorethylene etc.). Use of these solvents can reduce the mechanical reliability of the device. Use a cloth dampened in ethyl alcohol or water to clean the external plastic case.

1.Preface

ESM-1510N series temperature controllers are designed for measuring and controlling temperature. They can be used in many applications with their On / Off control form, heating and cooling control form and easy-use properties. Some application fields which they are used are below:

Application Fields	Applications
Glass	Heating
Food	Baking Ovens
Plastic	Incubators
Petro-Chemistry	Storages
Textile, Automotive	Air Conditioning
Machine Production Industries	Etc...

1.1 Operating Conditions

- Operating Temperature : -30 to 80 °C
- Max. Operating Humidity: 90% Rh (non-condensing)
- Altitude : Up to 2000 m.
- Forbidden Conditions: Corrosive atmosphere, Explosive atmosphere, Home applications (The unit is only for industrial applications)

1.2 General Specifications

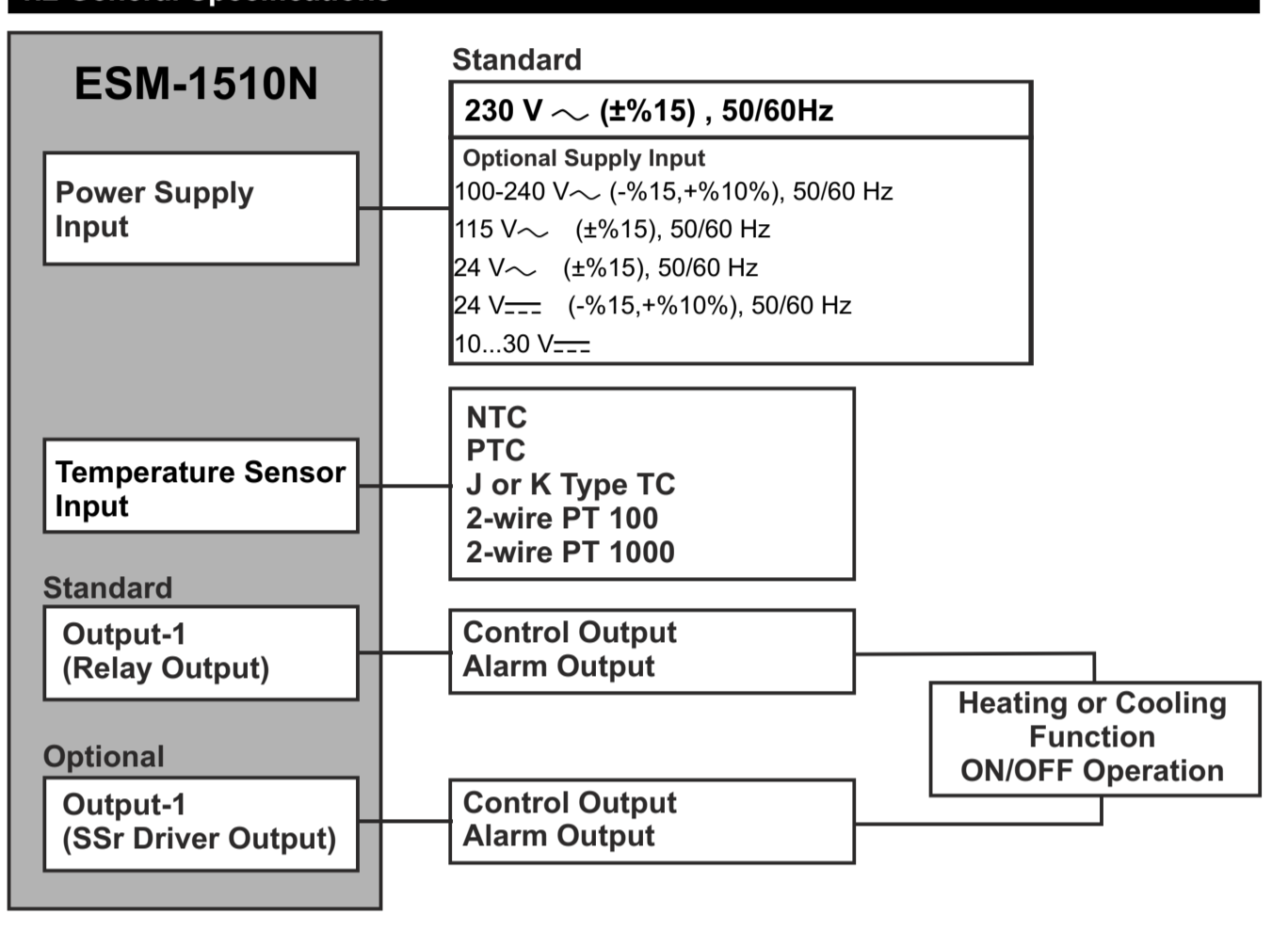

2 General Description

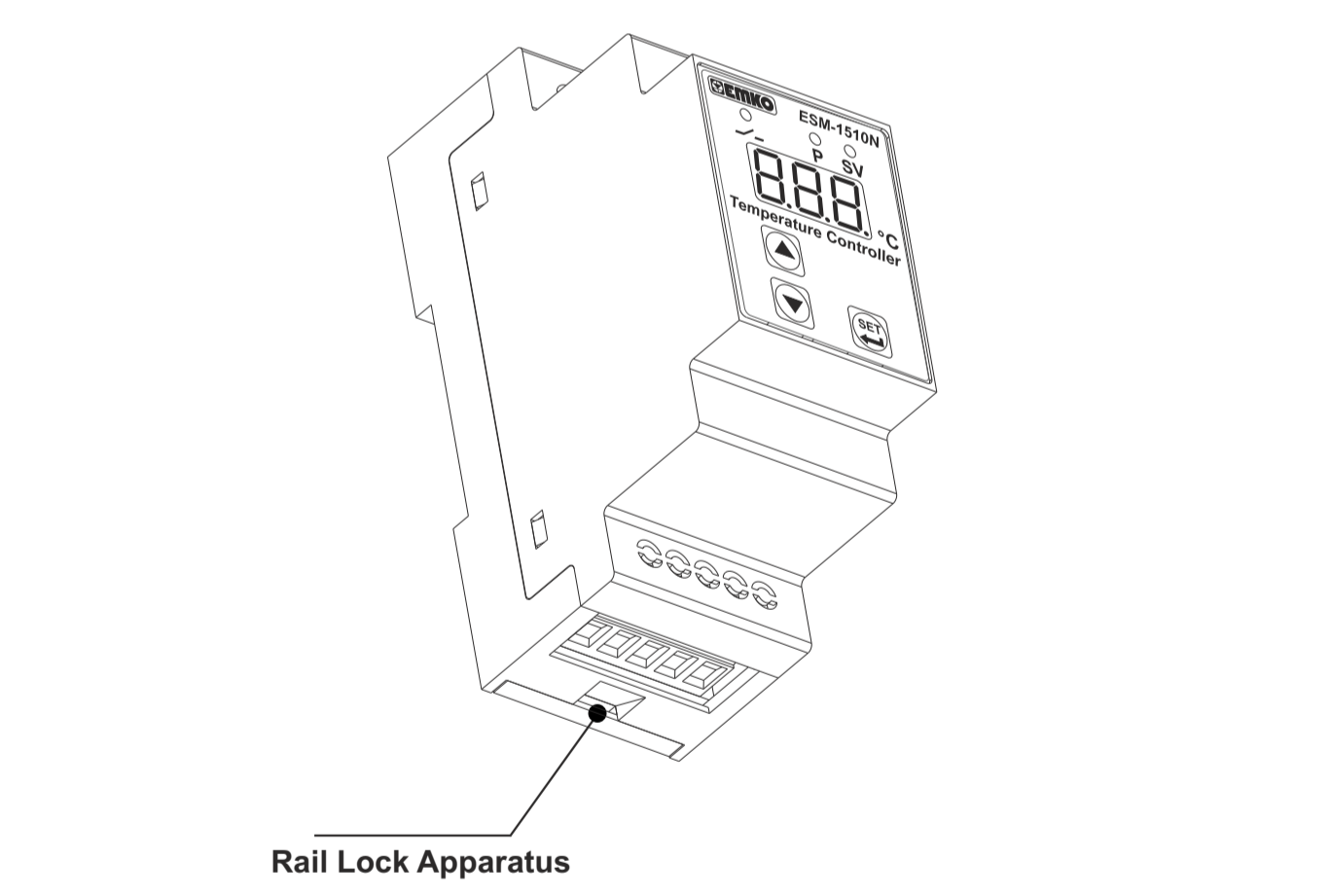

2.1 Front View and Dimensions of ESM-1510N Temperature Controller

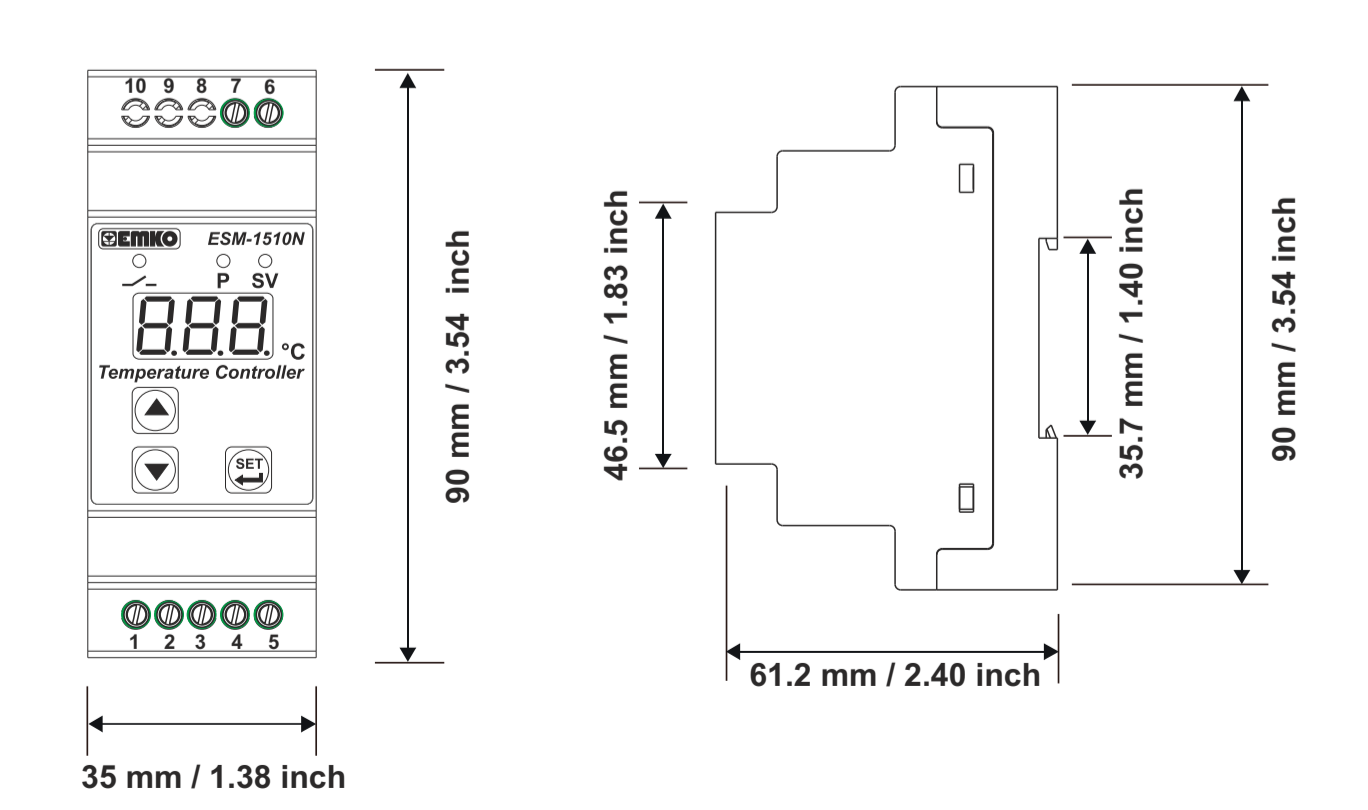

2.2 Installation onto the Rail

The unit is designed for rail mounting.

- Put into the unit upper side of the rail properly.
- Pull down the rail lock apparatus via a screw driver.
- Push the unit from the underside for mounting to the rail.

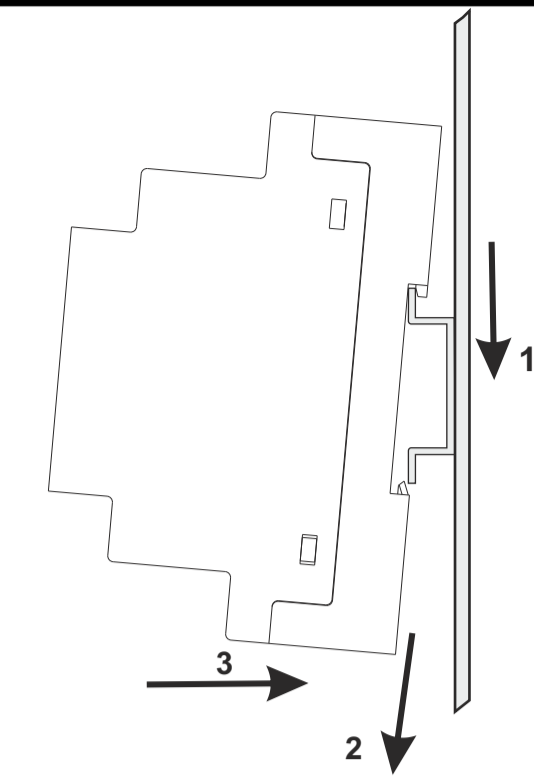

During installation onto the rail, care should be taken to avoid injury from mechanical part of the system. These precautions for the safety of the person who does the rail mounting.

2.3 Removing from the Rail

Before starting to remove the unit from the rail, power off the unit and the related system.

- Pull down the rail lock apparatus via a screw driver.
- Pull the unit from the underside to separate the rail lock apparatus from the rail.
- Pull up the unit to remove from the rail.

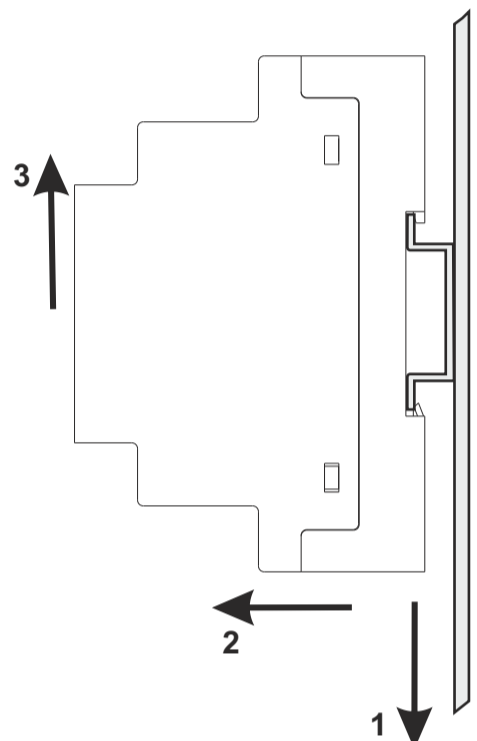

3. Electrical Wiring Diagram

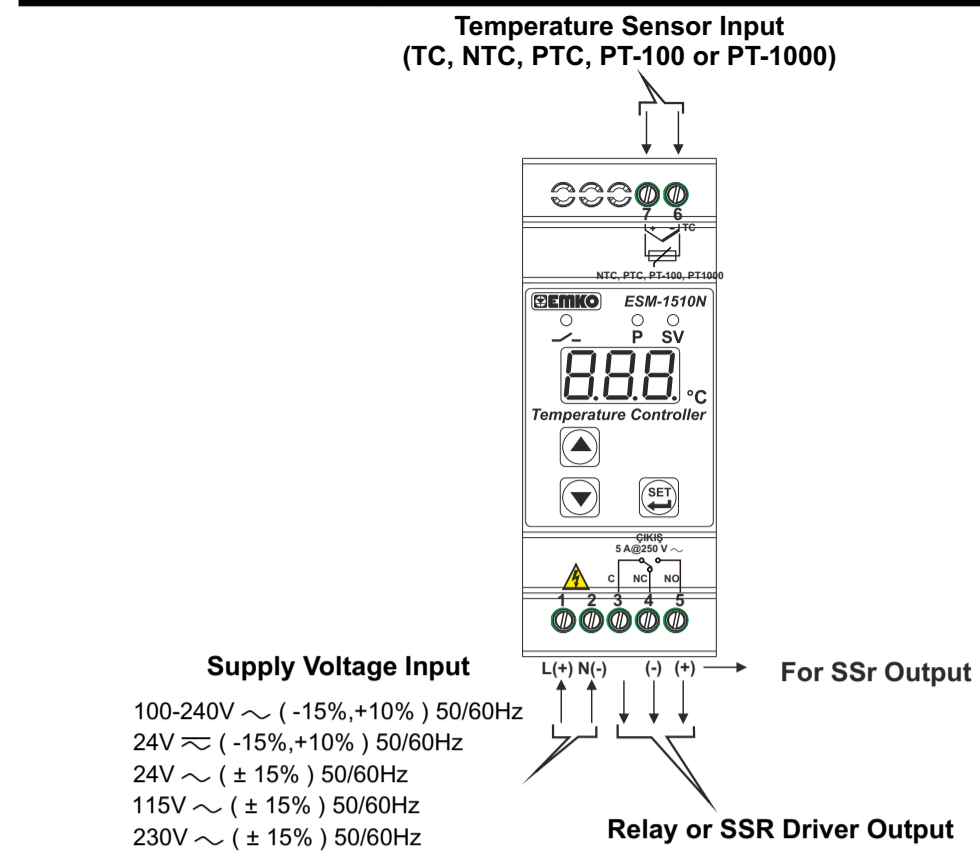

3.1 Supply Voltage Input Connection of the Device

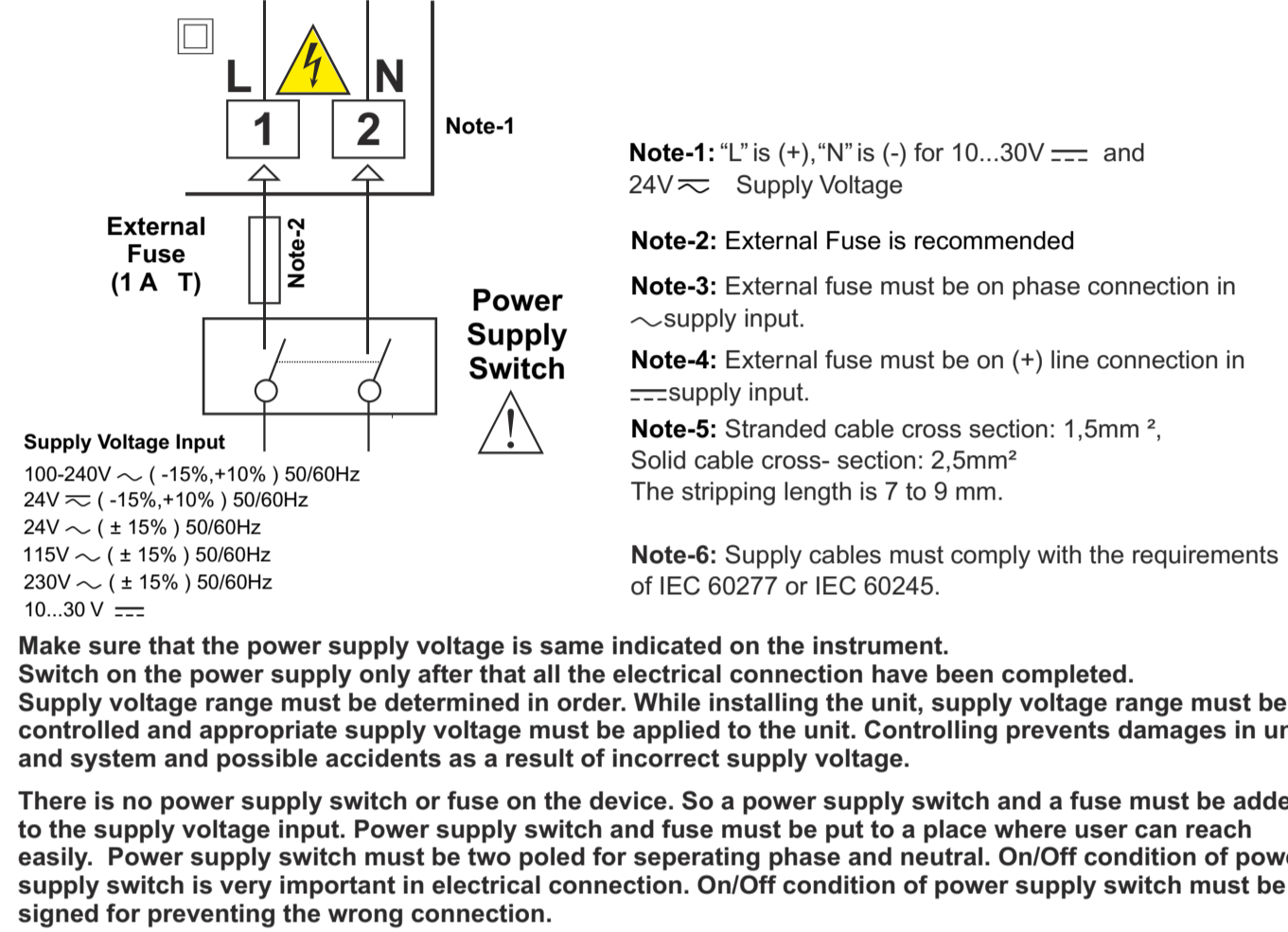

Make sure that the power supply voltage is same indicated on the instrument. Switch on the power supply only after that all the electrical connection have been completed. Supply voltage range must be determined in order. While installing the unit, supply voltage range must be controlled and appropriate supply voltage must be applied to the unit. Controlling prevents damages in unit and system and possible accidents as a result of incorrect supply voltage.

There is no power supply switch or fuse on the device. So a power supply switch and a fuse must be added to the supply voltage input. Power supply switch and fuse must be put to a place where user can reach easily. Power supply switch must be two poled for separating phase and neutral. On/Off condition of power supply switch is very important in electrical connection. On/Off condition of power supply switch must be signed for preventing the wrong connection.

4.2 Changing and Saving Set Value

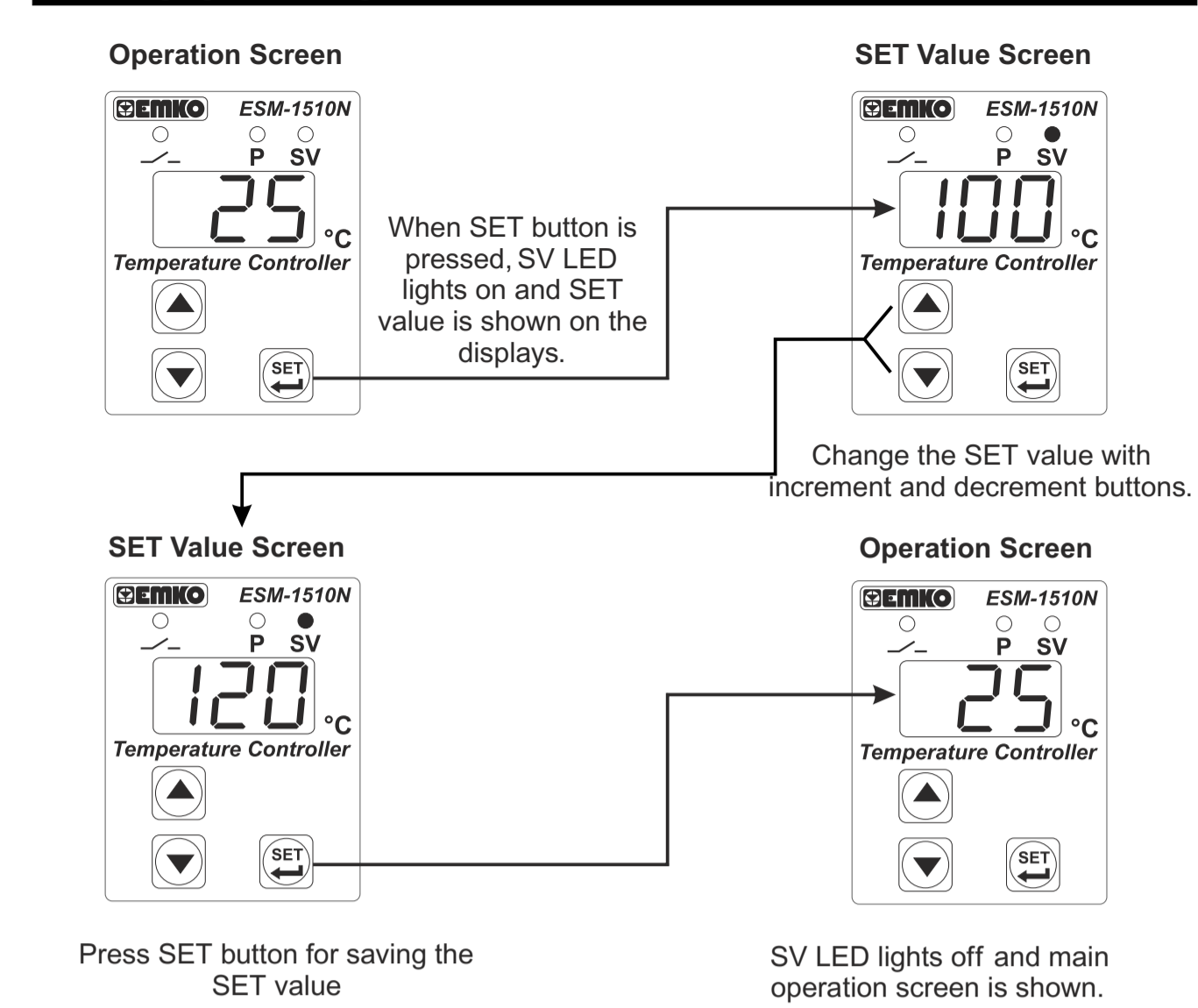

SET value is can be adjusted from minimum set value parameter $5uL$ to maximum set value parameter $5uH$, Which can be accessed from programming parameters.

If no operation is performed in Set value mode for 20 seconds, device turns to operation screen automatically.

3.2 Temperature Sensor Input Connection

3.2.1 TC (Thermocouple) Connection

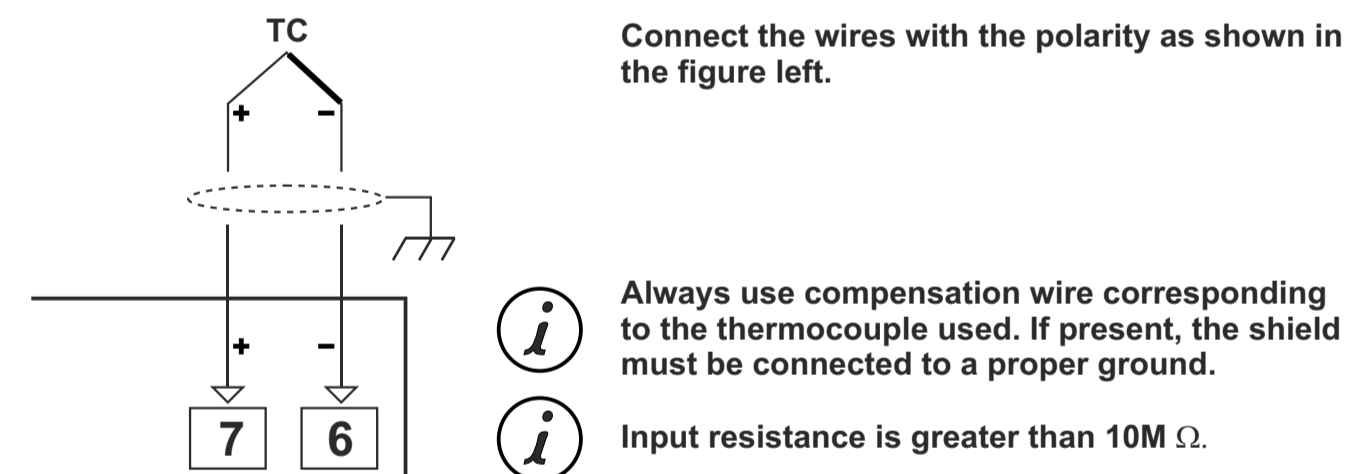

Connect the wires with the polarity as shown in the figure left.

- Always use compensation wire corresponding to the thermocouple used. If present, the shield must be connected to a proper ground.
- Input resistance is greater than 10M Ω .

3.2.2 PTC and NTC Connection

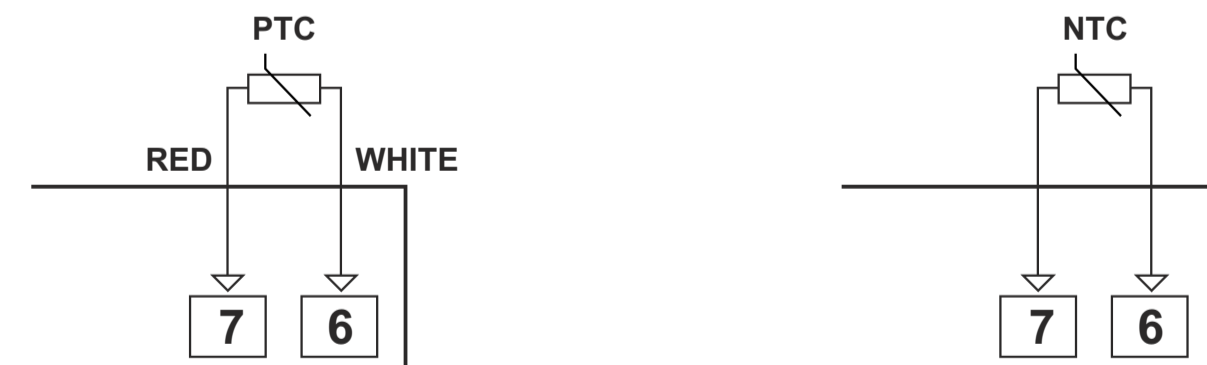

- Input resistance is greater than 10M Ω .
- Pay attention the cable colours of PTC probe while doing the PTC probe connection.

3.2.3 PT-100 and PT-1000 Connection

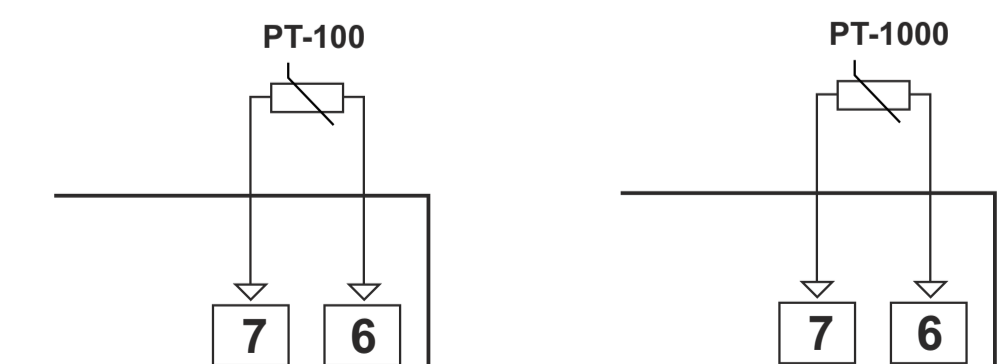

- Input resistance is greater than 10M Ω .

4. Front Panel Definition and Accessing to the Menus

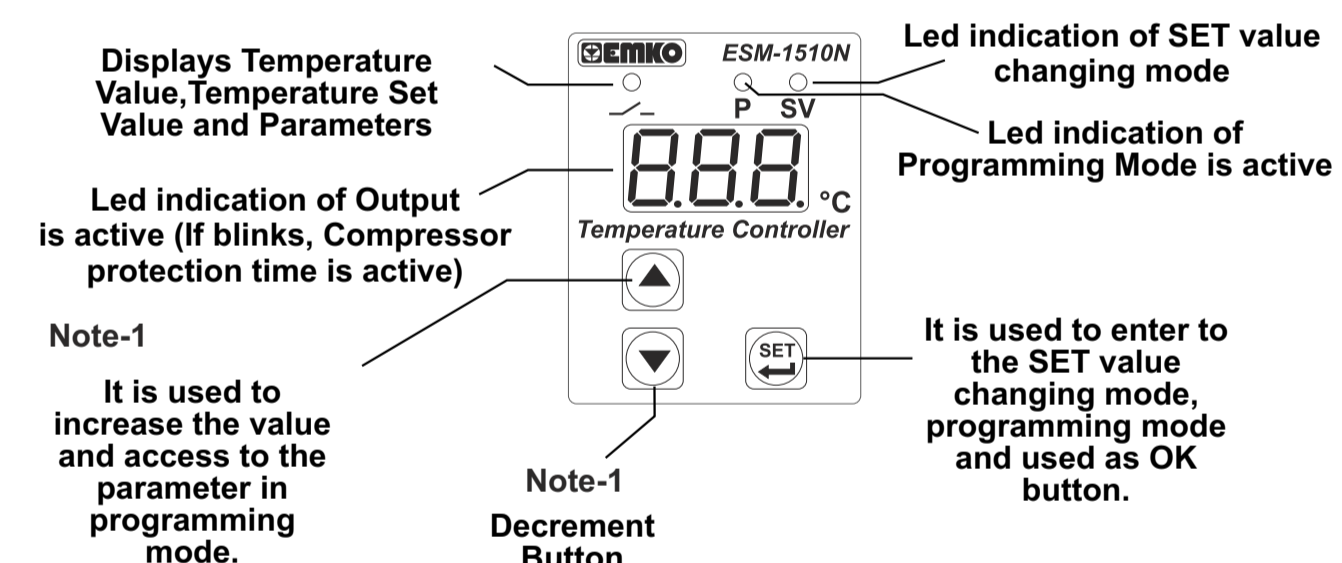

Note-1: If increment or decrement button is pressed for 5 seconds continuously, increment and decrement number become 10, if increment or decrement button is pressed for 10 seconds continuously, increment and decrement number become 100.

4.1 Observation of Software Revision on the Displays

When power is first applied to the temperature controller, software revision number is shown on the displays.

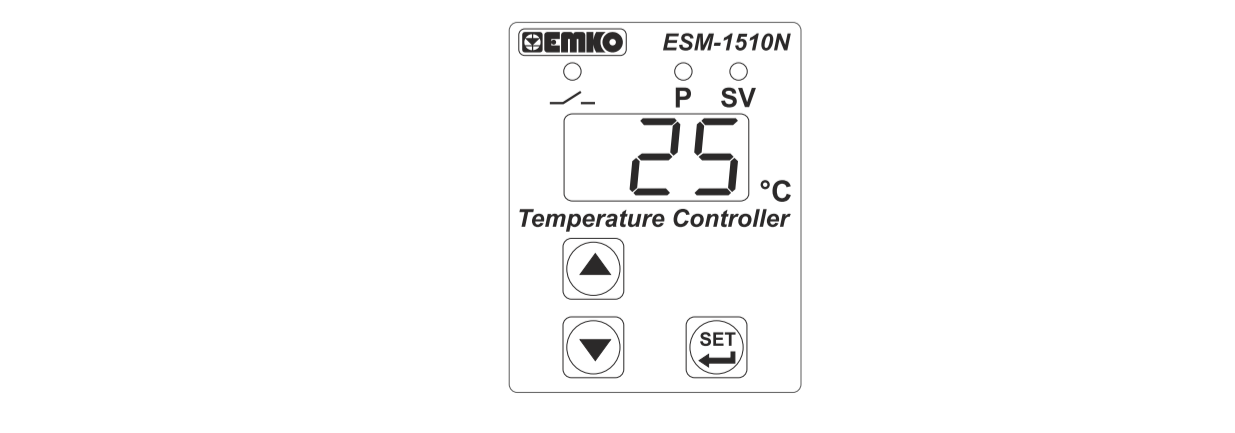
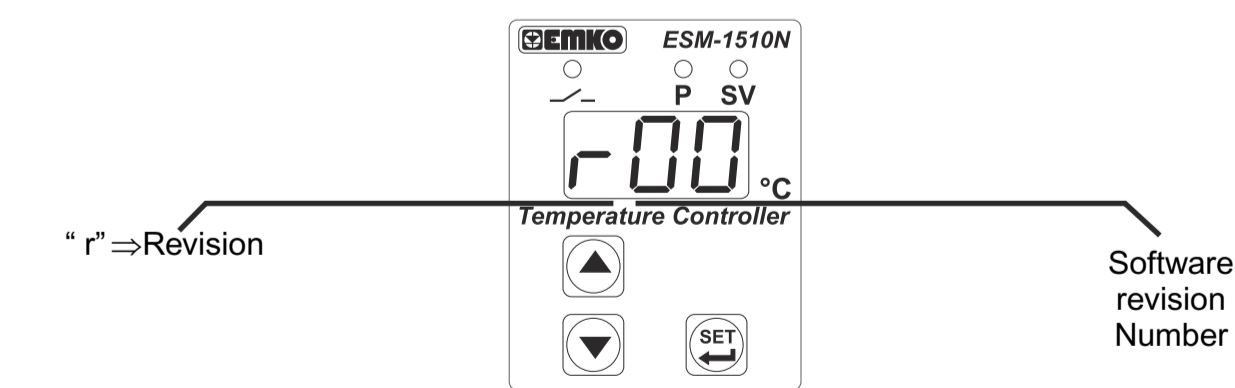

If there is an unexpected situation while opening the device, power off the device and inform a qualified personnel.

4.4 Working Graphics of ESM-1510N Temperature Controller

1-If Operating Type Parameter Value $HCS = 1$ (Cooling), Switch On Delay After Power On Parameter Value $Pos \geq 1$, Compressor Stop/Start Time Delay Parameter Value $SPd \geq 1$ and Compressor Start/Start Time Delay Parameter Value $Std \geq 1$;

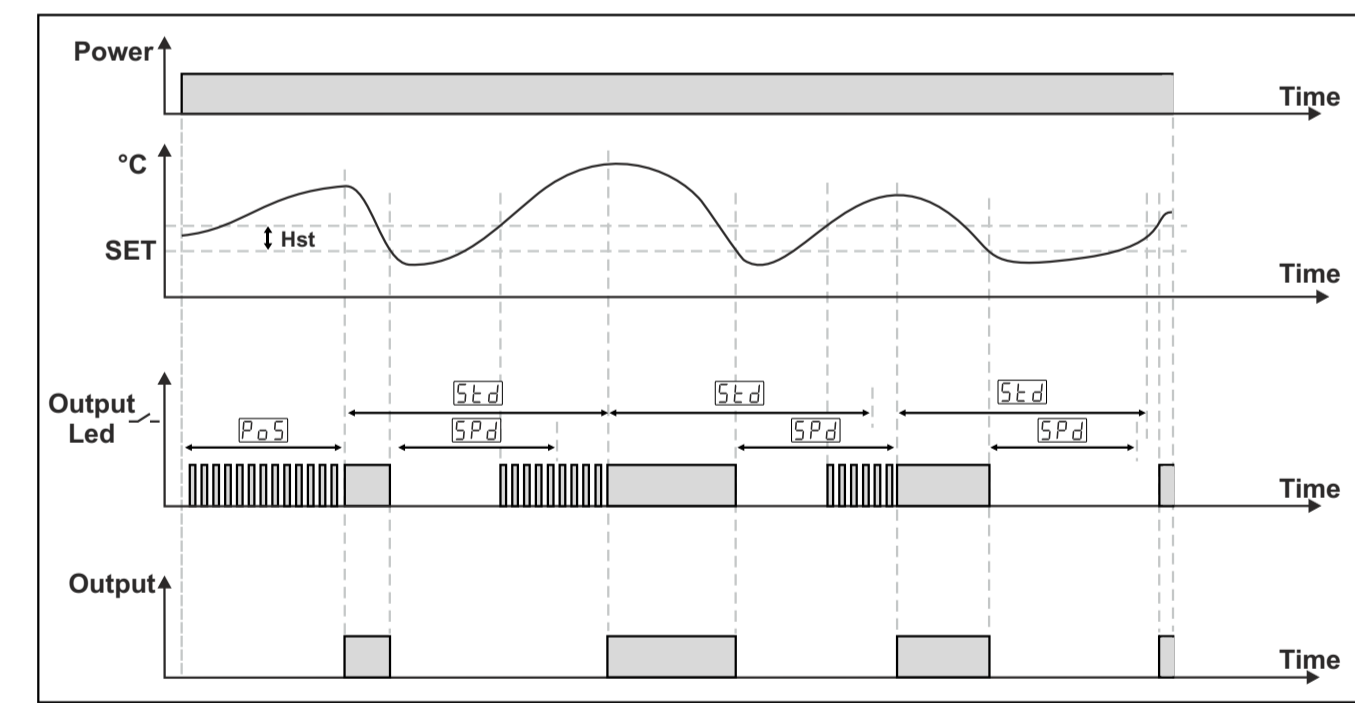

2-If Operating Type Parameter Value $HCS = 0$ (Heating),

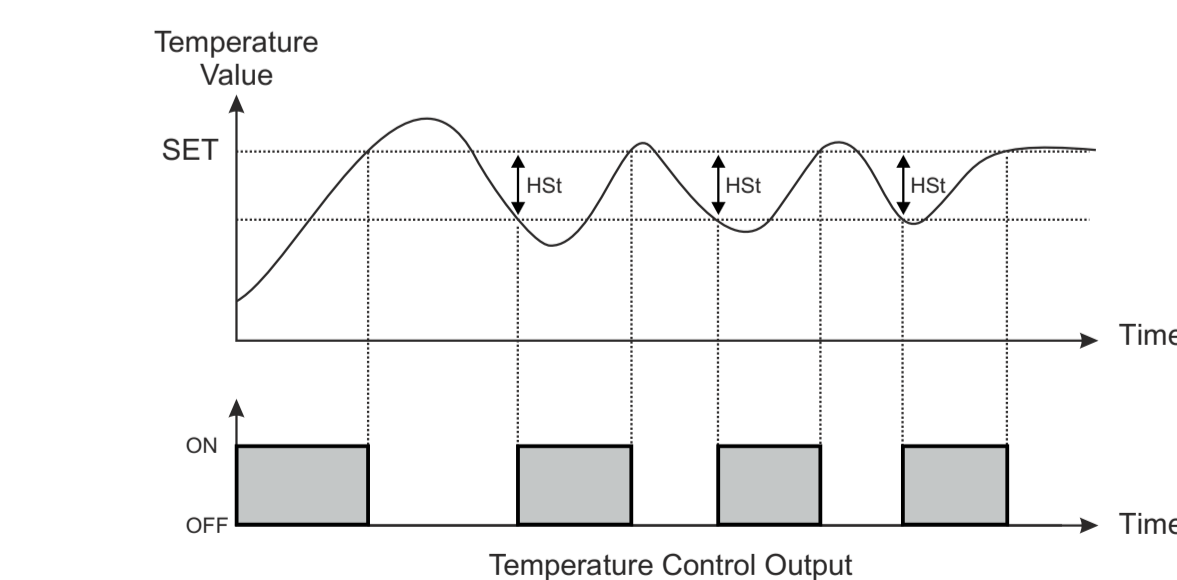

In ON/OFF control algorithm, temperature value is tried to keep equal to set value by opening or closing the last control element. ON/OFF controlled system, temperature value oscillates continuously. Temperature value's oscillation period or amplitude around set value changes according to controlled system. For reducing oscillation period of temperature value, a threshold zone is formed below or around set value and this zone is named hysteresis. Action of control output is described with figures above.

4.3 Program Parameters

- Pnt** Decimal Separator Enabling Parameter (Default = 0)
 - 0 Disable.
 - 1 Enable.
- Note: If sensor input type is selected PTC or NTC (BC= 12 or 18) is observed.
- Note: When Pnt parameter is changed, change Set, hSt, SuL, SuH, oFt parameters with appropriate values.
- HSt** Hysteresis Parameter for Output (Default = 1)
 - 1 to 100 C for TC Type Devices.
 - 1 to 100 C for PT-100 (-50 C, 400 C) and PT-1000 (-50 C, 400 C).
 - 0.1 to 10.0 C for PT-100 (-19.9 C, 99.9 C) and PT-1000 (-19.9 C, 99.9 C).
 - 1 to 20 C for PTC (-50 C, 150 C) and NTC (-50 C, 100 C).
 - 0.1 to 10.0 C for PTC (-19.9 C, 99.9 C) and NTC (-19.9 C, 99.9 C)
- SuL** Minimum Set Value Parameter (Default = Minimum value of device scale)
 - Set value can not be lower than this value. This parameter value can be adjusted from minimum value of device scale to maximum set value parameter $5uH$.
- SuH** Maximum Set Value Parameter (Default = Maximum value of device scale)
 - Set value can not be greater than this value. This parameter value can be adjusted from minimum set value $5uL$ to maximum value of the device scale.
- oFt** Process Offset Parameter (Default = 0)
 - 100 to 100 C for TC Type Devices.
 - 100 to 100 C for PT-100 (-50 C, 400 C) and PT-1000 (-50 C, 400 C).
 - 10.0 to 10.0 C for PT-100 (-19.9 C, 99.9 C) and PT-1000 (-19.9 C, 99.9 C).
 - 20 to 20 C for PTC (-50 C, 150 C) and NTC (-50 C, 100 C).
 - 10.0 to 10.0 C for PTC (-19.9 C, 99.9 C) and NTC (-19.9 C, 99.9 C)
- HCS** Operating Type Parameter (Default = 0)
 - 0 Heating
 - 1 Cooling
- Pos** Switch On Delay After Power On Parameter (Default = 0)
 - When power is first applied to the device, this time delay must be expired for activation of the compressor. It can be adjusted from 0 to 20 minutes.
- SPd** Compressor Stop/Start Time Delay Parameter (Default = 0)
 - When compressor is inactive, this time delay must be expired for activation of the compressor. It can be adjusted from 0 to 20 minutes.
- Std** Compressor Start/Start Time Delay Parameter (Default = 0)
 - This time delay must be expired between two activation of the compressor. It can be adjusted from 0 to 20 minutes.
- PdF** Probe Defect Parameter (Default = 0)
 - 0 Compressor is OFF in case of probe defect
 - 1 Compressor is ON in case of probe defect
 - 2 Compressor operates periodically according to Pon and Pof time periods in case of probe defect.
- Pon** Compressor is active during this time period in case of probe defect (Default = 0)
 - If Probe Defect Parameter PdF is 2, then this parameter can be observed. It can be adjusted from 0 to 99.
- Pof** Compressor is inactive during this time period in case of probe defect (Default = 0)
 - If Probe Defect Parameter PdF is 2, then this parameter can be observed. It can be adjusted from 0 to 99.
- PAS** Programming Mode Accessing Password (Default = 0)
 - It is used for accessing to the programming mode. It can be adjusted from 0 to 999.
 - If it is selected 0, password is not entered for accessing to the parameters.
 - Pos , SPd , Std , PdF , Pon and Pof parameters are observed if Operating type is selected "Cooling". If operating type is selected "Heating" beginning of the parameters list is shown.

4.5 Easy Access Diagram Of Programming Mode Parameters

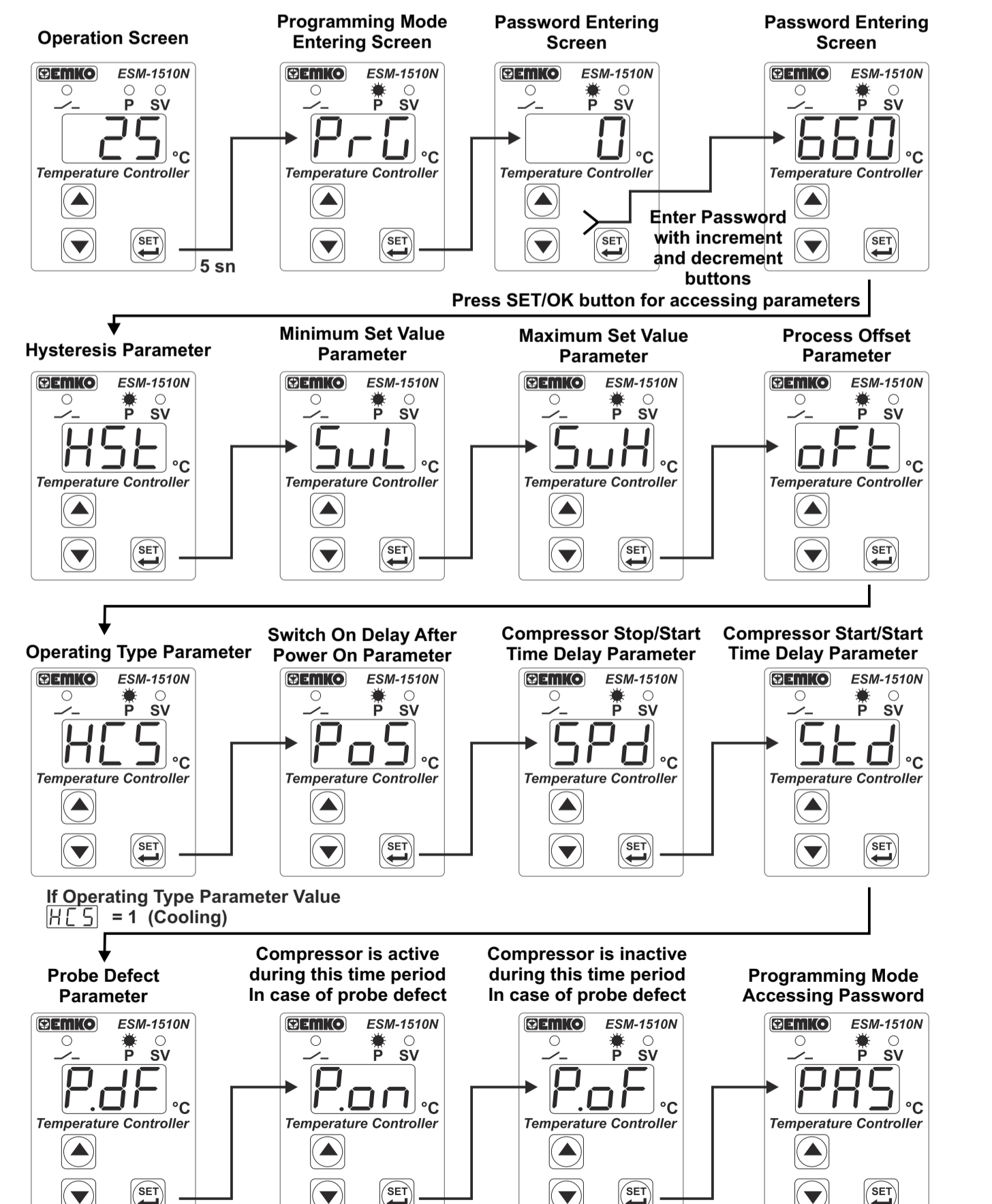

If there is an unexpected situation while opening the device, power off the device and inform a qualified personnel.